



# BLUE RIBBON Sales & Services Corp.

## BIRDCAGE®SERIES SUBMERSIBLE LEVEL TRANSMITTER MODEL BC001

The Patented Birdcage design provides a heavy duty 316 stainless steel protective stand off plate that protects the flush diaphragm from clogging.

### APPLICATIONS:

- Lift / Pump Station Sewage Level
- Sludge Level
- Oil and Gas Industry

### FEATURES:

- Patented Birdcage Design - Non-clogging sensor design
- Corrosion Resistant
- Rugged, Welded Stainless Steel Construction
- 4-20 mA , (0-5 VDC optional upon request)
- Polyurethane or Tefzel Reinforced Cable with Integral vent tube
- Enhanced surge & lightning protection
- Glycerine-filled, other fluids available
- \*\* FM, CSA, CE, AND/OR ATEX/IEC

Approval Available Upon Request – Consult Factory



### WIRING CODE

WIRE COLOR	BC001
RED	+ EXC./SIGNAL
GREEN	N/C
WHITE	N/C
BLACK	- EXC./SIGNAL
BLUE	N/C OPT. GH
BROWN	N/C OPT. GH
SHIELD	OPEN

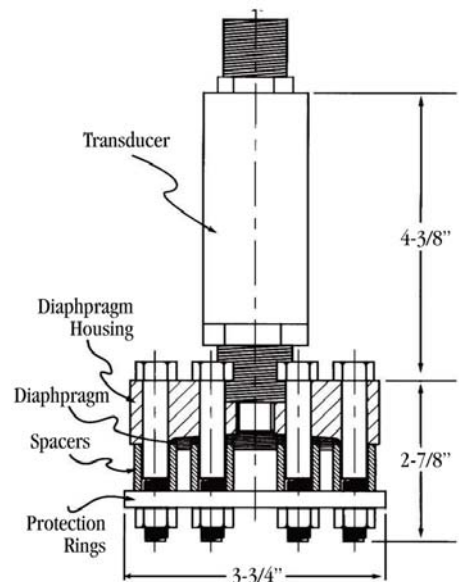

Blue Ribbon reserves the right to make product improvements and amendments to the product specifications stated throughout this brochure without prior notification. Please contact the factory on all critical dimensions and specifications for verification.

A5BR-BC001.00

477 Commerce Way, Suite 109, Longwood, FL 32750

Tel. (877) 677-8899 • Fax (407) 657-6622 • [brsales@blueribboncorp.com](mailto:brsales@blueribboncorp.com) • [www.blueribboncorp.com](http://www.blueribboncorp.com)



# BLUE RIBBON Sales & Services Corp.

Standard Specifications listed below.

Consult factory for further options, which may change the overall dimensions.

Output (at 70°F)	<b>Model BC001</b> 4-20mA 9.0 – 36 VDC Excitation 0-5 VDC 9.0 – 40 VDC Excitation - Optional		
Accuracy	<b>Static Accuracy</b> 0.25% FSO BFSL	<b>1 Year Stability</b> 0.20% FSO	<b>Error Band (with temp.)</b> 1.0% BFSL FSO
Pressure Ranges	<b>0-5 Ft.WC to 0-200 Ft.WC</b>		
Zero Balance (at 70°F)	± 1% FSO		
Range Calibration Signal	Internal Calibration Resistor set to 100 ±0.5% FSO unless otherwise specified		
Insulation Resistance	> 10 megohms @ 50 VDC & @ 70°F		
Temperature Limits	<b>Compensated</b> +35°F to +125°F	<b>Operating</b> -40°F to +190°F	<b>Storage</b> -65°F to +250°F
Temperature Compensation (Standard)	<b>Zero / Span</b> Less than ±2% FSO/100°F at FSPR and/or URL		
Electricals	<b>Load Impedance</b> 1350 ohms maximum at 36 VDC and 750 ohms maximum at 24 VDC <b>-RF, Protection</b> <b>-Volsurge Protection</b> <b>-Lightning Protection</b>		
Standard Connections	<b>Process Connection</b> 3-1/2" 316 SS Flush Diaphragm	<b>Electrical Connection</b> Polyurethane or Tefzel Reinforced Cable with Integral vent tube (40 Ft. Standard – other lengths available upon request)	
Mechanicals	<b>Proof Pressure</b> 2X FSPR (or URL)	<b>Burst Pressure</b> 5X FSPR (or URL)	
Pressure Response	≤ 5 ms to 90%		
Weight	5.5 lbs.		
Wetted Material	<b>Case</b> 316 Stainless Steel	<b>Cable</b> Polyurethane or Tefzel Reinforced Cable with Integral vent tube (40 Ft. Standard – other lengths available upon request)	

## ORDERING GUIDE:

MODEL	PRESSURE RANGE	CABLE LENGTH
●	— ●	— ●/●/●

MODEL: BC001 4-20mA

### PRESSURE RANGE

ORDER CODE	PSI	Ft. WC
001	- 5	11.53
002	- 10	23.07
004	- 15	36.60
017.5	- 17.5	40.37
020	- 20	46.14
025	- 25	57.67
030	- 30	69.21
100	- 100	230.70

### CABLE

**AA** 40' Poly Urethane Cable (Standard)  
**AA-CZ** Alternate Length of Cable  
**AA/CT** 40' Tefzel Cable (Standard)  
**AA/VDC** 0-5 VDC  
 (Custom lengths of cable available upon request)

477 Commerce Way, Suite 109, Longwood, FL 32750

Tel. (877) 677-8899 • Fax (407) 657-6622 • brsales@blueribboncorp.com • www.blueribboncorp.com